



Goodwin

150 mm NZE 90kW 50Hz SUBMERSIBLE SLURRY PUMPS

NUMBER ONE FOR RELIABILITY, STRENGTH & ENDURANCE

TECHNICAL DATA SHEET

150 mm NZE **90kW 50Hz**

SUBMERSIBLE SLURRY PUMPS

Goodwin submersible pumps have been manufactured since 1982 and are recognised as market leaders in terms of performance and reliability. The pumps have been continually developed over 4 decades resulting in machines that can perform in the most demanding environments.

Standard Engineering Features

- Single piece cast iron motor housing to enhance rigidity and reduce wear
- 3 phase electric motor runs in oil bath to lubricate and cool the motor parts
- Cooling assisted by the pumped fluid passing through the pump body
- Twin volute casing design to reduce rotational imbalance and increase lifetime of bearings and seals
- Rotating inducer creates hydrodynamic shock waves to re-suspend settled particles beneath the pump inlet
- Carefully chosen wear resistant materials to maximise service lifetime
- Single stage, open vane impeller
- Precision bearings
- Non pressurised mechanical seal

Applications

- Open pit mine dewatering
- Mine tailings recovery and reprocessing
- Minerals processing - separation, purification, concentration
- Power plant ash removal and cleaning
- Lagoon dredging and silt removal
- River water and dam desilting
- Harbour and dry-dock cleaning
- Steel slag transport
- Rolling mill scale and metal cutting swarf transport
- Sewage and waste transfer

Pump Performance

Design fluid handled	Slurry
Maximum fluid SG	2.5 kg/l
Maximum fluid solids content	65 % by weight
Maximum particle size	54 mm
Maximum fluid temperature	90 °C
Recommended pH range	4-10
Weight (excluding cable)	2020 kg
Outlet diameter	150 mm
Maximum flow	380 m ³ /hr
Maximum head	25 m (2.4 bar)
Impeller diameter	410 mm
Impeller tip speed	21 m/s
Peak efficiency	44 %
Maximum submergence depth*	28 m
Shut off head at maximum pump speed	25 m

* as standard, can be deeper if required

Electrical Data

Motor type	Vertical, oil filled, squirrel cage induction
Frequency	50Hz
Phase	3
Motor rating	IEC 60034-1
Protection class	IP68
Starting method	Direct on Line (DOL), Soft Start, Variable Speed Drive. Note: Star Delta not available
Power	90 kW
Speed	960 rpm - 6 pole
Number of starts per hour	10
Voltage variation	+/- 6%
Voltage imbalance between phases	Max 2%
Insulation class	H (180°C)
Motor overload factor	2.2
Duty rating	S1
Efficiency class	IE exempt (integral with pump)
Oil type	Mineral uninhibited to IEC 60269 (04)
Standards complied with	IEEE 112-2004, IEC 60034-1-2, AS60034-1, JEC 37
Noise level at 1m when not submerged	78 dB
Motor efficiency	90%



Electrical Data

Voltage (V)	Rated power (kW)	RPM	Rated (full load) Current (A)	Inrush Current Soft Start (A)	No Load Current (A)	Power Factor cos ϕ (full load)	Power Factor cos ϕ (75% load)	Power Factor cos ϕ (50% load)	Recommended Over Current Protection (A)
380	90	960	171 A	600 A	40 A	0.91	0.82	0.81	350 A
415	90	960	160 A	560 A	38 A	0.91	0.82	0.81	350 A
525	90	960	128 A	450 A	30 A	0.91	0.82	0.81	300 A
660	90	960	97 A	335 A	23 A	0.91	0.82	0.81	300 A
1000	90	960	64 A	225 A	17 A	0.91	0.82	0.81	250 A

Materials

Pump body castings	SG Iron
Impeller	Tungsten carbide coated NiHard
Casing	NiHard
Wear plate	Tungsten carbide coated NiHard
Inducer	Tungsten carbide tiled and coated hardened stainless steel
Shaft	Martensitic stainless steel
Mechanical seal	Stainless steel and silicon carbide
O-rings	Nitrile rubber
Fasteners	Stainless steel

Coating System

Surface preparation	Class 2.5
Undercoat	Two component high build epoxy coating. 125 μ m thickness (typical).
Top coat	Acrylic polyurethane high gloss. 50 μ m thickness (typical). Yellow to RAL 1003 / BS4800 08-E-51.

Other Data

Recommended cable	Heavy duty 70mm ² 3 phase + earth copper cored cable with black chlorinated polyethylene (CPE) rubber sheathing. To standard EN 50525-2-21. Voltage rating 750V. Outer sheath is oil resistant to IEC 60811-404, flame resistant to IEC 60332-1-2. Maximum external diameter 46.7mm. Weight 4.2kg/m.	
Recommended lifting chains	Length: 0.6 m	Material: Steel SWL: 3200 kg
Hose connection	Outlet flange configuration	150mm PN10 M20*2.5P 8 Places ϕ 240mm PCD
Cable gland	Material	Nickel plated brass (stainless steel optional)
	Specification	BS6121:Part 1:1989
Control panel	Rating	IP65
	Weight	108kg
	Description	Voltage protection, earth leakage protection, phase imbalance, automatic operation with level switch and timer. Soft start as standard (VSD optional).

150 mm NZE 90kW 50Hz

SUBMERSIBLE SLURRY PUMPS

Dimensions

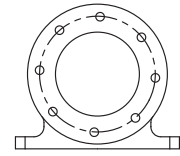
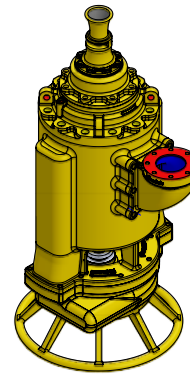
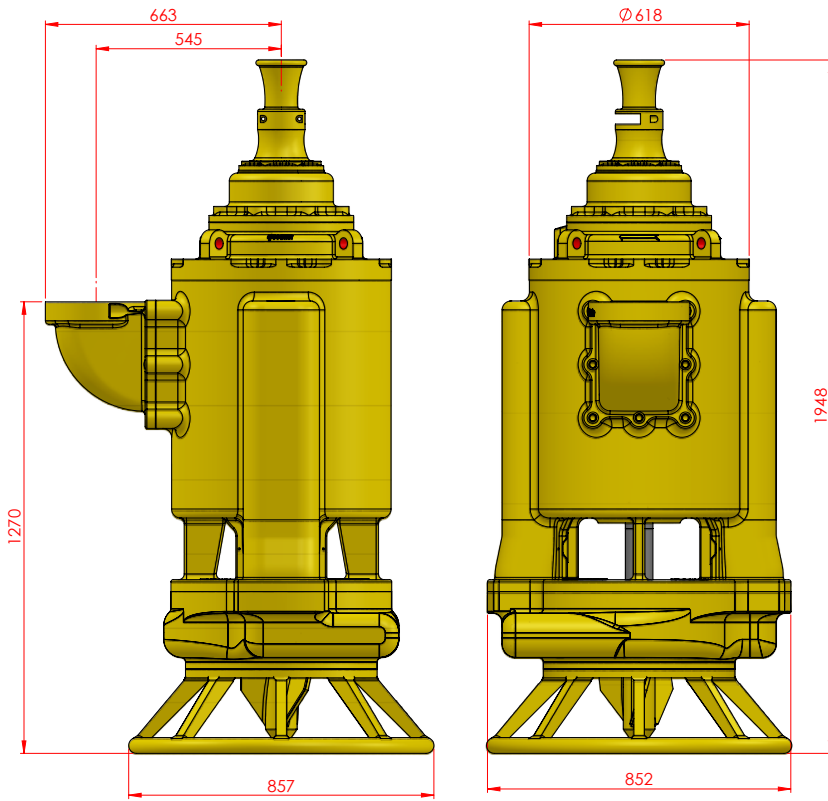

150mm PN10
M20*2.5P
8 Places
ø240mm PCD

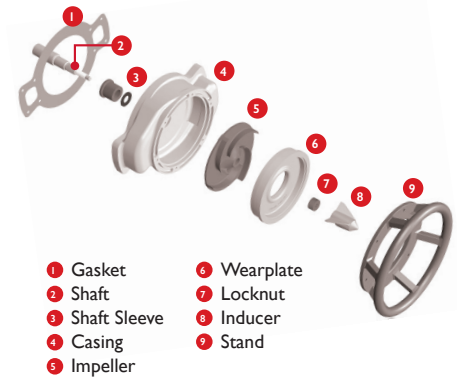

Pump Curve

